

**CHICAGO
FAUCETS**
Geberit Group

The 90 Series Family

Valves for Food Service Applications



Complete Family of Valves

90 Series low flow pre-rinse valve for food service applications.

The 90 Series Pre-Rinse features a durable metal valve body, handle and nozzle for long product life, as well as superior performance. Easy to install on existing products or as an alternative spray on all complete Chicago Faucets pre-rinse fittings and available as a standard pre-rinse spray or in these special-use configurations:



**45° Angle
Pre-Rinse**

90-ANGABCP



**Hose
Reel Spray**

90-HABCP

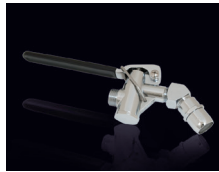

**45° Angle
Glass Filler**

90-ANGE3ABCP



**Gooseneck
Filler**

90-GNABCP

The 90-LABCP

Dependable

Stainless steel post and screw feature Phillips heads, are easily accessible, and allow for simple field replacement of handle assembly.

Heavy Duty

Heavy duty, tool-free, field replaceable bumper slides over nozzle and locks into place.

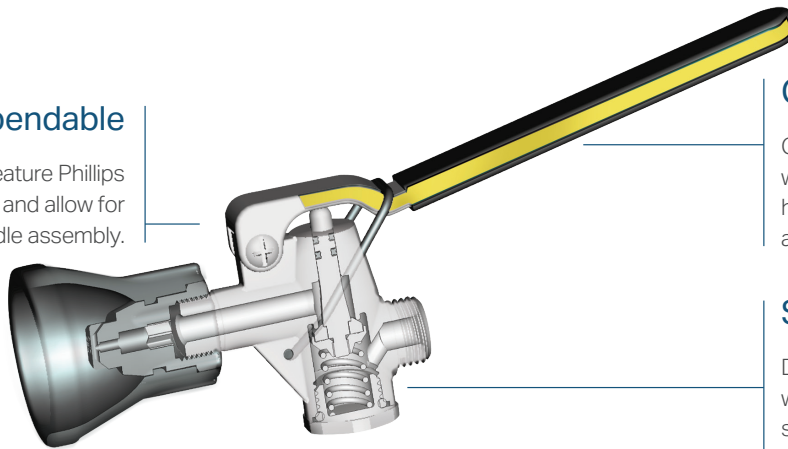

Performance

Field replaceable one piece stainless steel nozzle with 1.0 gpm @ 60 PSI performance.

Convenient

Chrome plated brass handle with PVC coating and integrated hold-down clip for durability and convenience.

Smooth Activation

Durable solid brass valve body with nickel plated brass valve stem provides smooth valve activation.

Ease of Use

3/4"-14 UNS male thread allows standard attachment.

Conservation and savings.

The 90-LABCP Pre-rinse reduces water usage and utility expenses by almost 30%* while maintaining work efficiency.

*Based on 3 hours of daily usage and industry average utility costs, industry standard 1.42 gpm, and "low-flow" competitor rate of 1.28 gpm.

Annual Water Usage

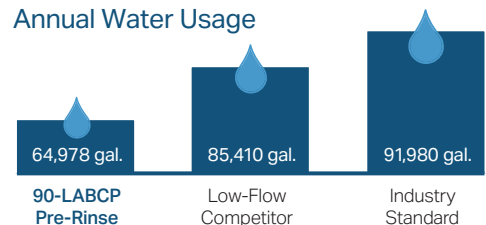

Codes & Standards

Certified to NSF/ANSI 61, Section 9 by CSA

NSF/ANSI 372

ASME A112.18.1M/CSA B125.1 Certified

ASTM F2324-03

90 Series is compliant to California Health and Safety Code 116875 (AB 1953-2006) and Vermont Bill S. 152