

8453 Series User Guide Installation Instructions

Installation instructions for 8453 series faucets

CHICAGO FAUCETS
Geberit Group

Safety Information

- Read entire user guide to ensure proper installation. Compliance and conformity to local codes and ordinances is the responsibility of the installer. Please follow these important safety guidelines while handling and installing this product:
- FCC Caution: Any changes or modifications not expressly approved by the party responsible for compliance could void the user's authority to operate this equipment
 - Make sure there is enough space and lighting available during installation and service.
 - Do not modify or convert this product before, during, or after installation. Doing so voids all warranties

Internal Antenna Specifications

- Peak Gain of the antenna: +1.51 dBi
- Frequency range: 2400-2500 MHz
- FCC ID: 2APTX-CFC03

This equipment has been tested and found to comply with the limits for a Class B digital device, pursuant to Part 15 of the FCC Rules. These limits are designed to provide reasonable protection against harmful interference in a residential installation. This equipment generates uses and can radiate radio frequency energy and, if not installed and used in accordance with the instructions, may cause harmful interference to radio communications. However, there is no guarantee that interference will not occur in a particular installation. If this equipment does cause harmful interference to radio or television reception, which can be determined by turning the equipment off and on, the user is encouraged to try to correct the interference by one of the following measures:

- Reorient or relocate the receiving antenna.
- Increase the separation between the equipment and receiver.
- Connect the equipment into an outlet on a circuit different from that to which the receiver is connected.
- Consult the dealer or an experienced radio/TV technician for help.

This device complies with Part 15 of the FCC Rules. Operation is subject to the following two conditions: (1) This device may not cause harmful interference, and (2) this device must accept any interference received, including interference that may cause undesired operation.

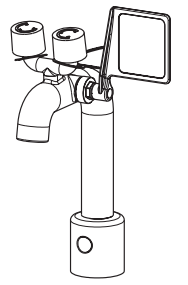

8453 Series

Notice to the Installer

- Read this entire instruction sheet before installing to ensure proper installation.
- Installation must comply with local codes and ordinances.
- Do not use sealing compound. Possible solenoid contamination could occur and will void any warranty.
- Exercise care when installing the device to prevent marring the exposed, decorative surfaces.

Pressurized plumbing fixtures shall be installed in accordance with manufacturer's recommendations. The supply piping of these devices shall be securely anchored to the building structure to prevent installed device from unnecessary movement when operated by the user. Care shall be exercised when installing the device to prevent marring the exposed surface.

NOTE: The information in this manual is subject to change without notice. Please leave this manual with the facility manager after completing the faucet installation. This document contains information necessary for routine maintenance and servicing. Before installation, turn off water supplies to existing faucet and remove faucet if replacing. Clean faucet basin and clear away debris. Flush all supply lines before connecting to faucet. Failure to do so can result in debris clogging the inlets and/or cartridges.

Water Supply

The water supply to the Emergency Eyewash equipment should meet the following conditions:

- Water must be supplied directly from the main or dedicated emergency piping that supplies potable water or water of similar quality.
- An inlet pressure of 50psi is recommended. For proper operation, the minimum pressure is 22 psi (1.5 bar), and the maximum pressure is 116 PSI (8 bar).
- Flush and drain the supply line before installing the Emergency Eyewash. An inline water filter is recommended.

NOTE: Water supply must be tepid water with a temperature between 60°F and 100°F (16°C and 38°C) to comply with ANSI standards.

The faucet comes complete and ready to install. You will need the following tools and supplies to complete the installation:

- Basin Wrench
- Adjustable Locking Pliers
- Drill
- Adjustable Wrench
- Rubber Mallet or Hammer

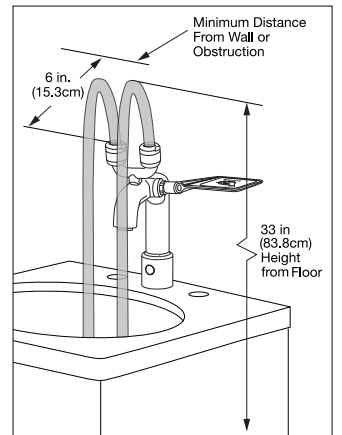

Installation - Eyewash Faucet Body

1. Insert mounting rod into bottom of spout.
2. Place spout with gasket and escutcheon with o-ring, hoses, and sensor wires through hole in deck.
3. Lower assembly to deck and verify proper seating.
4. Position spout so that it is square with backsplash.
5. Place hoses, sensor wires and threaded rod through bracket.
6. Tighten nut so that gasket is fully depressed with no movement in spout.
7. Assemble push paddle with supplied screw.
8. Make sure that the paddle is at 90° vertical. Adjust as necessary by loosening cap, setting at 90°, then tightening cap.
9. Spout is now ready to connect with valve assemblies.
10. Connect the eyewash supply (designated by red tag) to the tepid water supply line.

NOTE: If your installation includes an ASSE 1071 compliant tempering valve, please see the instructions provided with the valve for proper connection to the eyewash fitting.

WARNING! Delivery of water to fixtures intended for hand washing is recommended to be controlled by valves listed to ASSE 1070. This fitting is NOT factory preset and can be adjusted to deliver water at temperatures exceeding 110°F (43°C). Further, mechanical mixing valves DO NOT provide automatic control of water temperature. Due to effects of various water conditions, periodic verification of outlet water temperature is required.

Spout hose (865.963.00.0) is not to be used as a pressurized supply line and is only for connecting faucet to the control box.

Mounting Control Box

1. Remove the control box cover by using a #2 Phillips screwdriver to loosen the cover screw.
2. Pivot the yellow locking tab and remove the metal key at the top of the control box. Apply silicone-based lubricant to the end of the spout hose and insert it through the hole.
3. Be sure to seat the hose firmly before reinstalling the metal key and securing it with the yellow locking tab.
4. Determine the position of the control box under the sink. Hold the control box against the wall and mark the locations of the two mounting holes. Orientation is not critical.
5. Drill 3/16" holes, install wall anchors and mounting screws. Be sure to leave at least 1/2" (12mm) of the screw head exposed. Secure the control box to the wall using a #2 Phillips screwdriver.

Connecting Water Supply (dual supply unit shown)

1. Insert the filter screen gaskets into the supply stops.
2. Attach the 3/8" female compression supply hoses from the control box to the supply stops. Use a wrench to tighten the nuts to the supply stops.
3. Open the supply stops and check for leaks. Note: water may run through spout.

IMPORTANT: The filter screen gaskets seal the connection against leaks and must be installed as shown.

IMPORTANT: Remove any debris or hardware from the sink before opening the supplies and testing the faucet.

Connecting Power and Solenoid

1. Bring wire into box. Use length of box for measurement. Snap into holder on side.
2. Attach power connections as shown in the following sections.

Battery (DC) Power

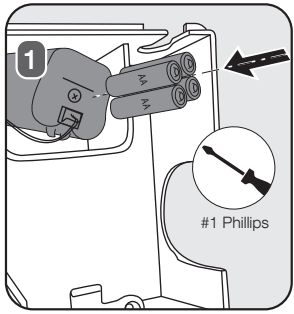

i. Open the yellow battery housing and insert 4 'AA' batteries according to the diagram inside the housing. NOTE: Make sure the batteries are oriented properly before testing the faucet.

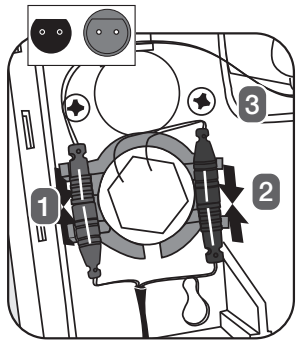

ii. Attach the wiring connectors (gray to gray, black to black). Note: Connectors are keyed for proper installation as shown. Snap completed connections, into the wiring harness as shown.

LTPS (DC) Power

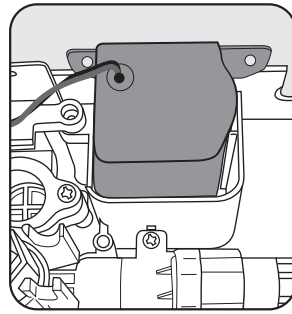

i. Insert LTPS into upper compartment of box, aligning slots with compartment ribs. Attach LTPS adapter wiring connectors (green to green). First green to green, then gray to gray. Note: the connectors are keyed for proper installation.

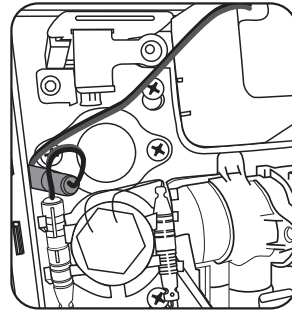

ii. Connect wiring connectors, first gray to gray, then black to black. (Note: the connectors are keyed for proper installation) Snap the completed connections, into the wiring harness as shown. Tuck the completed green connection into the space as shown.

(AC) Power

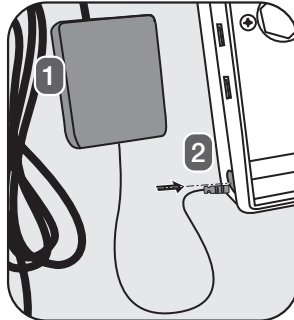

i. Choose a location and mount the transformer. Run the cable from the transformer through the opening in the control box.

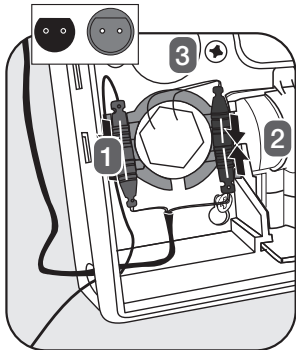

ii. Attach the wiring connectors (gray to gray, black to black). Note: connectors are keyed for proper installation as shown. Snap completed connections, into the wiring harness as shown.

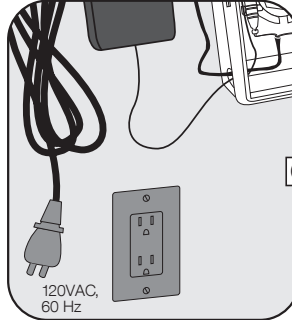

iii. Plug the transformer into the wall.

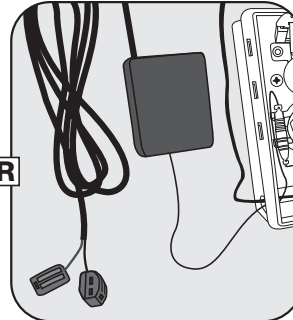

iv. Wire up the transformer to the main line.

Testing unit - Eyewash

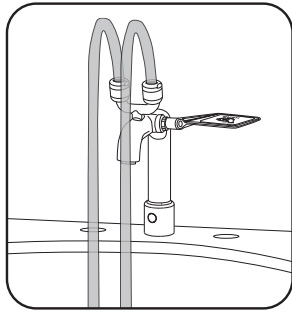

1. Flush eyewash portion of faucet. Activate by pushing on paddle. The paddle should move freely, with no resistance during activation.

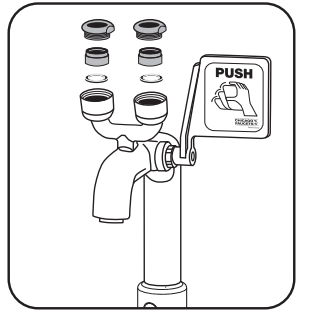

2. Install washer, aerator, and eyewash cap assembly. Secure into place.

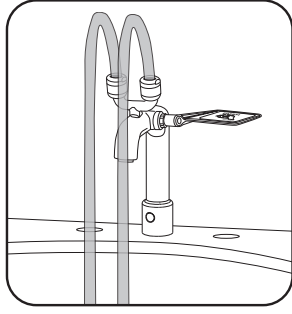

3. Activate again. Ensure water flows in a smooth, consistent stream. Use a thermometer to check water temperature. **Note: must be between 60°F and 100°F.**

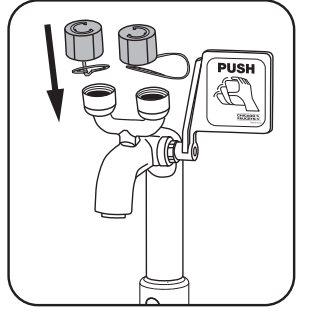

4. Pull paddle back to stop flow and place eyewash covers on faucet.

LTPS End of Life Directives (Recycling) In an effort to produce environmentally conscious products, the LTPS contains materials that are required to be recycled by specialized companies. Please ensure you dispose of your LTPS according to local regulations. Follow applicable laws and regulations for transport, shipping, and disposal of batteries. For details on, and locations for recycling lithium based batteries, please contact a government recycling agency, your waste-disposal service, or visit reputable on-line recycling sources such as www.call2recycle.org.

Completing Installation: Testing and Adjustment

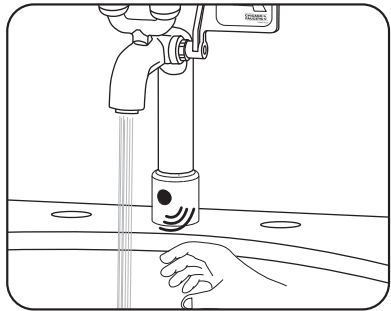

1. Once wiring is complete, the red sensor light at the faucet outlet will glow continuously for 5 seconds. After the light switches off, place your hands in front of the faucet. The faucet should activate and water should flow.

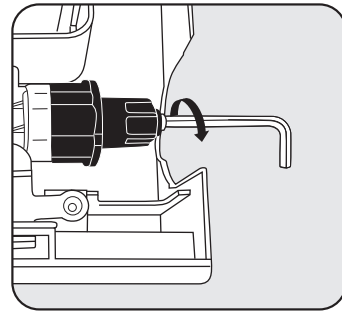

2. Adjusting the Water Temp.
a. Loosen the cap screw until the handle turns freely (do not remove the screw) with a 3mm (7/64") hex wrench.

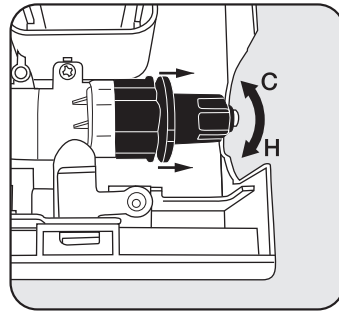

b. Cap must be partially pulled from valve to adjust temperature. Turn clockwise to decrease temperature or counter-clockwise to increase temperature.
c. Push in cap. Tighten cap screw.

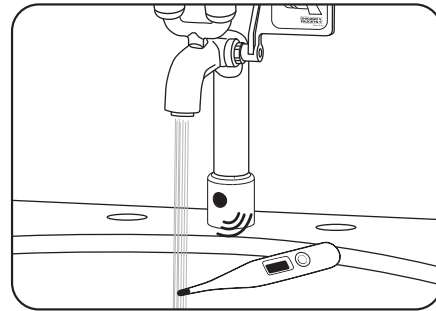

d. Mixed water temperature must be checked at the point of use and the CFC mixing valve adjusted to ensure delivery of water at a safe temperature not exceeding 110°F (43°C). Water temperatures in excess of 110°F (43°C) are dangerous and may cause scalding, severe injury or death!

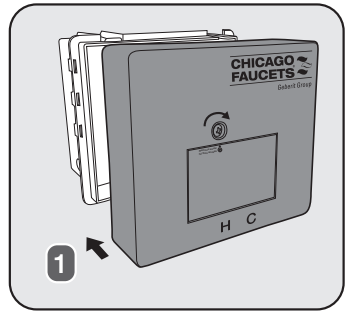

3. Reinstall control box cover. Secure with #2 Phillips screw.

Faucet Adjustment Overview

Operating modes and sensor ranges can be adjusted with a manual operation through the infrared sensor. A traditional lavatory faucet is shown as an example. Faucet adjustment operations apply to all models. Alternatively, operating modes and sensor ranges can be adjusted with the Chicago Faucets Commander™ Handheld Programming Unit. For more information, visit chicagofaucets.com/commander.

Operating Modes	Description
Cleaning Mode	The faucet is inactive for 90 seconds.
Normal Mode	The faucet is activated if it senses a hand presence. This is the default operating mode of the faucet.
Metering Mode (10 s)	The faucet will shut off after 10 seconds regardless of hand presence detected.
Scrub Mode (60 s)	The faucet will shut off 60 seconds after the detection of the last hand presence.
Scrub Mode (180 s)	The faucet will shut off 180 seconds after the detection of the last hand presence.
Sensor Range Adjustment	Change the detection distance of the infrared sensor. The default sensor range is approximately 1" beyond the spout.
Reset	All settings will be reset to original factory settings.

In order to set the operating modes, the faucet needs to be placed into "Manual Setting" mode. At this time, operating modes can be changed within the next 30 minutes. If you do not have a Commander Programming Unit and would like to manually change modes, contact 1-800-832-8783 for instructions.

Flow Data

Pressure PSI (Bar)	20 (1.38)	40 (2.76)	60 (4.14)	80 (5.52)	100 (6.89)
Flow Rate GPM (L/Min)	2.25 (8.52)	3.2 (12.11)	3.95 (14.95)	4.6 (17.41)	5.25 (19.87)
Stream Distance "A" Inches (Cm)	5.0 (12.7)	7.5 (19.1)	9.5 (24.1)	12.0 (30.5)	14.0 (35.6)

QUICK TROUBLESHOOTING

Follow the steps below to fix common problems. For detailed troubleshooting, visit chicagofaucets.com. Before troubleshooting, remove any objects in detection zone and make sure sensor is clear of debris. Ensure power is applied and solid red light appears during first 5 seconds after power-up.

The faucet is leaking:

From outlet – tighten or replace outlet insert using included key.
From supply stops – install or replace filter screen gaskets (see diagram on pg. 1).

No water flow or flow is limited:

Make sure supply hoses are connected and supply stops are fully open. Clean or replace filter screen gaskets or outlet insert.

Water flow does not stop:

If water flows continuously but stops when hand enters detection zone, reverse solenoid electrical connections.

Faucet does not properly detect user:

Remove and reapply power or run faucet to maximum run time. This will cause automatic recalibration of sensing field. Recalibration is complete when solid red light disappears.

If the steps above do not solve the problem, you may need to replace the spout assembly or control box. Contact customer service at 800/832-8783.

Care and Maintenance

Periodic inspection and yearly maintenance by a licensed contractor is required for all thermostatic mixing elements. Corrosive water conditions and/or unauthorized adjustments or repair could render the thermostatic valve ineffective for service intended. Regular checking and cleaning of the valve's internal components and check stops helps assure maximum life and proper product function. Frequency of cleaning and inspection depends on local water conditions. All Chicago Faucets fittings are designed and engineered to meet or exceed industry performance standards. Care should be taken when cleaning this product. Do not use abrasive cleaners, chemicals, or solvents as they can result in surface damage. Use mild soap with warm water for cleaning and protecting the surface of Chicago Faucets fittings.

For additional technical assistance, call 800/TEC-TRUE (800-832-8783) or visit our website at chicagofaucets.com.

CHICAGO FAUCETS LIMITED WARRANTY

TO WHOM DOES THIS WARRANTY APPLY? – The Company extends the following limited warranty to the original user only.

WHAT DOES THIS WARRANTY COVER AND HOW LONG DOES IT LAST?

This warranty covers the following Commercial Products:

LIFETIME FAUCET WARRANTY – The "Faucet," defined as any metal cast, forged, stamped or formed portion of the Product, not including electronic or moving parts or other products separately covered by this Limited Warranty or water restricting components or other components, is warranted against material manufacturing defects for the life of the Product.

FIVE YEAR FAUCET WARRANTY – Certain Products and portions of the Product are warranted against material manufacturing defects for a period of five (5) years from the date of Product purchase. Products warranted against material manufacturing defects for a period of five (5) years from the date of Product purchase are referred to by the product numbers 42X, 43X, 15XX and E-Tronic® - 4X, 5X, 6X, 7X, 8X and 9X. All zinc die cast portions of Product are warranted against material manufacturing defects for a period of five (5) years from the date of Product purchase.

THREE YEAR ELECTRONICS WARRANTY – Electronic components, including the solenoid, are warranted for three (3) years from the date of installation.

FIVE YEAR CARTRIDGE WARRANTY – The "Cartridge", defined as the metal portion of any Product typically referred to by the product numbers containing 1-099, 1-100, 377X, 217X and 274X, excluding any rubber or plastic components, is warranted against material manufacturing defects for a period of five (5) years from the date of Product purchase. All Cartridges included in the Company's Single Control or Shower Products also are warranted against material manufacturing defects for a period of five (5) years from the date of Product purchase.

ONE YEAR FINISH WARRANTY – COMMERCIAL – For Products used in commercial applications, the finish of the Product is warranted against material manufacturing defects for a period of one (1) year from the date of Product purchase.

OTHER WARRANTIES – All other Products not covered above are warranted against material manufacturing defects for a period of one (1) year from the date of Product purchase.

Other restrictions and limitations apply. For complete warranty details, call Chicago Faucets Customer Service at 847-803-5000 or visit chicagofaucets.com.

The Chicago Faucet Company
2100 South Clearwater Drive
Des Plaines, IL 60018
Phone: 847/803-5000
Fax: 847/849-1845
Technical: 800/832-8783
www.chicagofaucets.com