

Pressure Balance Valve Installation Instructions

1921 Series Shower Valve with Integral Auto-Drain™

Notice to the Installer

Notice to the Installer

- Read this entire instruction sheet before installing to ensure proper installation.
- Installation must comply with local codes and ordinances.

Pressurized plumbing fittings shall be installed in accordance with manufacturer's recommendations.

The supply piping to these devices shall be securely anchored to the building structure to prevent installed device from unnecessary movement when

operated by the user. Care shall be exercised when installing the device to prevent marring the exposed surface.

NOTE: The information in this manual is subject to change without notice.

Please leave this manual with the facility manager after completing the valve installation. This document contains information necessary for routine maintenance and servicing.

NOTE: The information in this manual is subject to change without notice.

Please leave this manual with the facility manager after completing the valve installation. This document contains information necessary for routine maintenance and servicing.

Mixing Valve

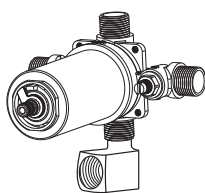

1921-VONF

Diverter Valve*

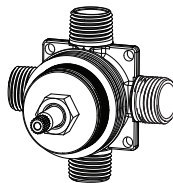

773-VONF

Hand Shower Elbow

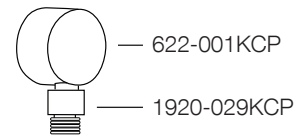

— 622-001KCP

— 1920-029KCP

Mixing Valve Trim

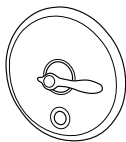

1921-001KCP

Diverter Valve Trim



773-TPCP

Auto-Drain Only



1920-022KCP

Hand Shower Complete Kit

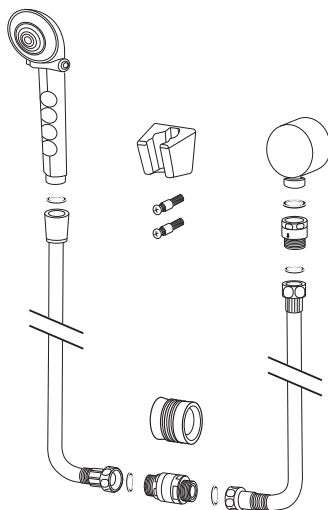

150-ADCP

IMPORTANT! Setting Hot Limit Stop

The removal of the warning label barrier on the face of this mixing valve constitutes the transfer of liability from the manufacturer to the installer under the laws of the United States. It is the installer's responsibility to set the maximum output temperature of the valve to no more than 120°F, in accordance with Standard ASSE 1016/ASME A112.1016/CSA B125.16 dealing with individual thermostatic, pressure balancing, and combination pressure balancing and thermostatic control valves for individual fixtures, temperature limit setting.

*U.S. Patent Pending

Rough-In of Valve and Assembly of Trim:

1. Unthread and remove the Integral Stops using a socket wrench equipped with a 9/16" deep well socket (see Figure 1). Remove valve cartridge. Use plastic guard as template to rough valve body into wall.
2. Depth of rough-in should account for thickness of wall materials to be used (combined thickness of wall board and finished wall material). The distance from the centerline of the inlet/outlet ports of the valve assembly to the finished wall MUST be between 1-15/16" – 2-5/8". See images below for reference.
3. Make sure valve is positioned plumb and level. Remove rough-in template from valve. Make threaded connections or plumb and solder all joints and fittings. Take care to protect surrounding area when soldering. Secure piping to surrounding structure.
4. Reinstall the integral stops using a socket wrench equipped with a 9/16" deep well socket or adjustable wrench. Reinstall valve cartridge.
5. Valve should be pressurized and tested for leaks at the connections.
6. Plastic guard should be left attached to the valve until finished wall material is installed.
7. After wall is finished, remove plastic guard and install drain and trim

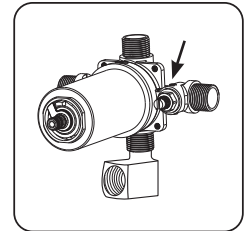
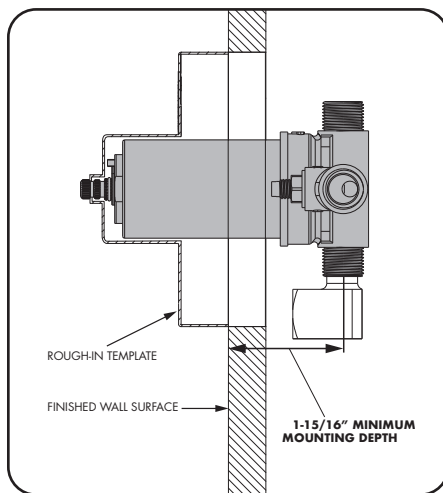
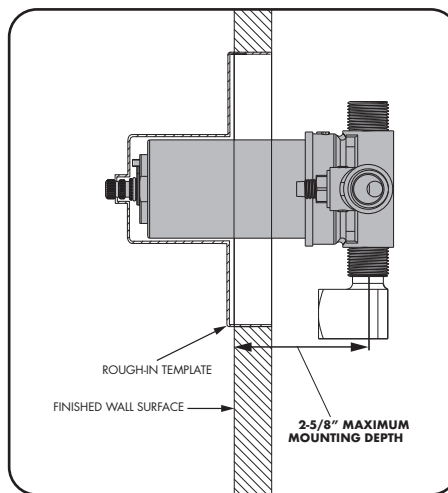

Figure 1



Mixing Valve Minimum Mounting Depth



Mixing Valve Maximum Mounting Depth

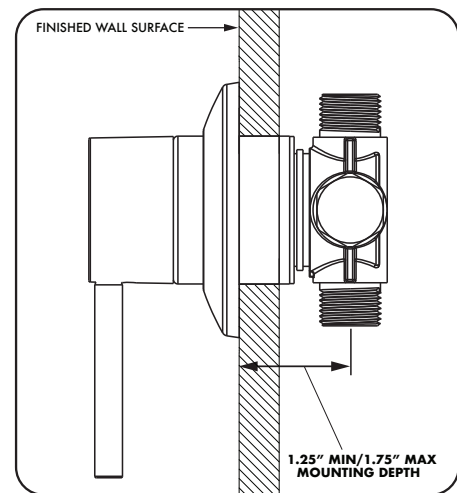

Diverter Valve Mounting Depth

Elbow and Pipe Installation

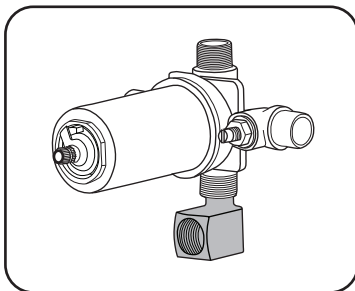

1. Install valve with brazed elbow.

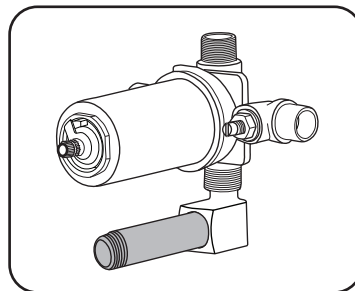

2. Install straight nipple 1/2" pipe – 1/2-14 NPT both ends. Use pipe sealer on both ends of nipple. Tighten securely with wrench. Take care not to damage chrome plate finish.

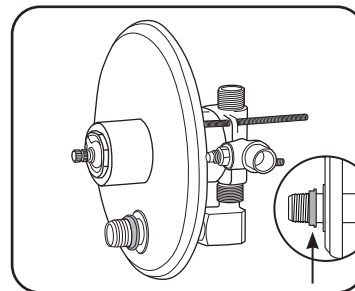

3. Position 2-hole round trim over valve and pipe and attach with screws. Insert pipe and drain seal with larger diameter end closest to the trim.

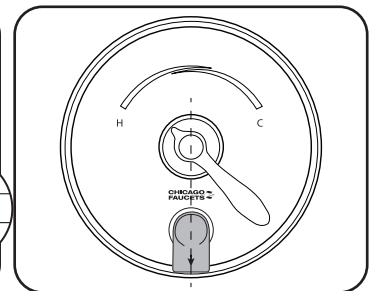

4. Make sure drain holes are lined up vertically and drain cap is tightly secure.

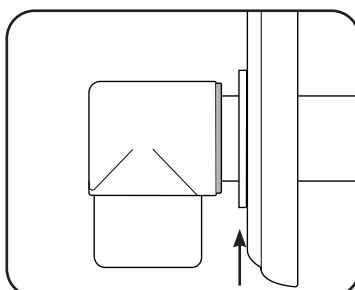

5. Push seal inside the drain back opening until it seats flush against the drain body.

Installation Configurations (cont)

1. Hand Shower with Trim Integrated Valve and Shower Hose Drain

1. Install lower valve drain following steps on pg 2.
2. For hand shower, install a short supply pipe up from valve and attach a 45° elbow (B).
3. Run extension supply pipe from the elbow to desired location that is 18" - 24" above valve center, maintaining a 45° angle (C). ½-14 NPT thread is required for hand shower exposed elbow installation.
4. Apply thread seal tape and install exposed elbow (D). (Model no. 1920-029KCP)
5. Install atmospheric vent with included gasket (E).
6. Install hose segments to elbow and hand spray.
7. Connect the end of each hose segment to hose drain valve (F).
8. Hand spray holder should be placed at same height as exposed elbow and positioned so the drain valve is centered at the lowest point in the hose (G).

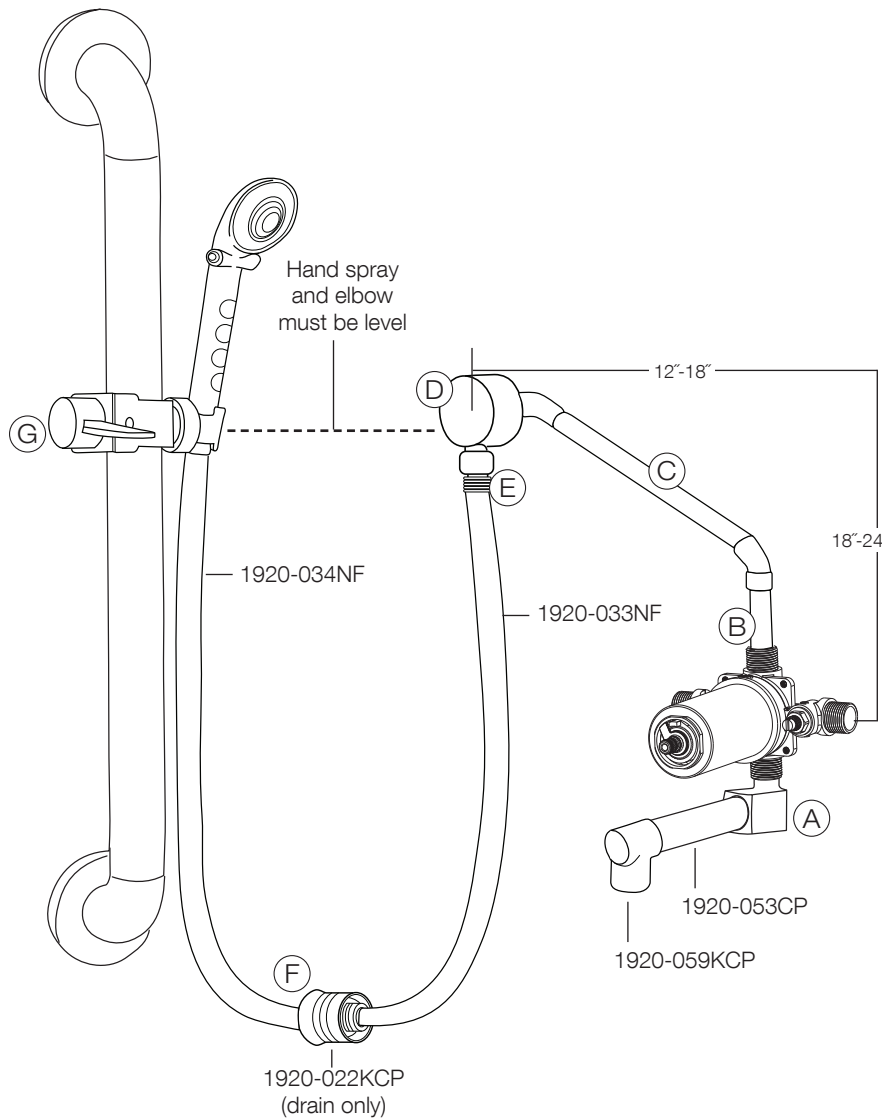

NOTE: In order for the Auto-Drain system to function properly with a hand shower, the supply pipe to the exposed elbow must be at a 45° angle. Also, the Auto-Drain for the hand shower hose must be centered at lowest point when hanging. If hand spray holder is moved during use, it must be returned to original position – level with elbow – to ensure proper drainage.

Installation Configurations

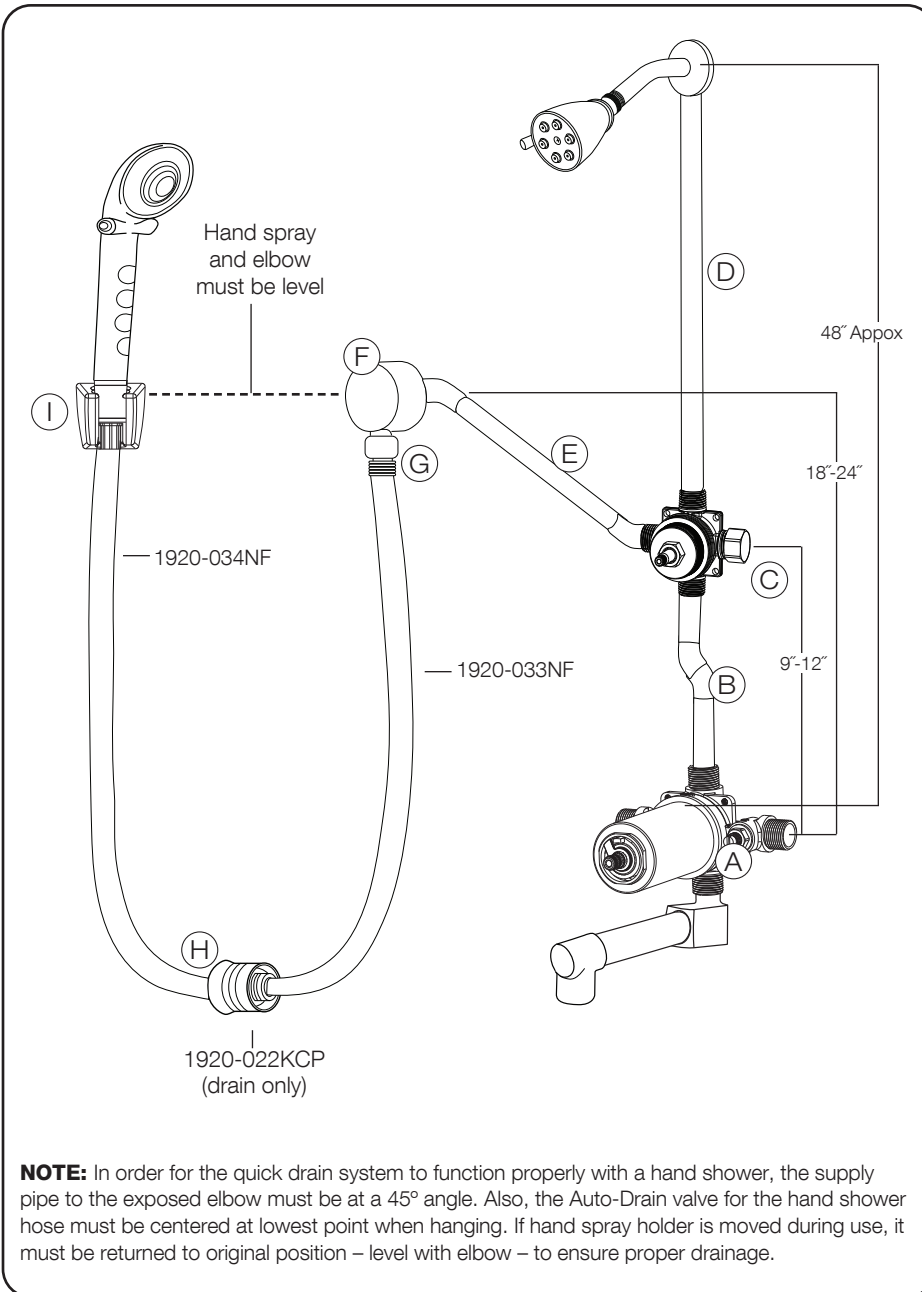

2. Hand Shower with Valve and Shower Hose Auto-Drain

1. Install lower valve drain following steps on pg 2.
2. Run extension supply pipes from the mixing valve and the diverter valve. There may be a difference in mounting depths that may require an offset connection (B). If there is a difference in mounting depths, two 45 degree elbows are recommended.
3. Install the diverter valve. Apply thread seal tape to the unused outlet port and install the included cap (C). Wrench tighten.
4. For the shower head, run extension supply pipe (D) from the diverter valve to desired location that is approximately 48" above mixing valve center.
5. For hand shower, run an extension supply pipe from diverter valve to the desired location of the elbow to that is 18" - 24" above mixing valve center, maintaining a 45° angle (E). 1/2-14 NPT thread is required for hand shower exposed elbow installation.
6. Apply thread seal tape and install exposed elbow (F).
7. Install atmospheric vent with included gasket (G).
8. Install hose segments to elbow and hand spray.
9. Connect the end of each hose segment to Auto-Drain (H).
10. Hand shower holder (I) must be placed at same height as exposed elbow and positioned so the drain valve (H) is centered at the lowest point in the hose.

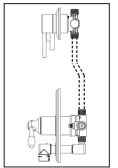

Back-to-Back Installation

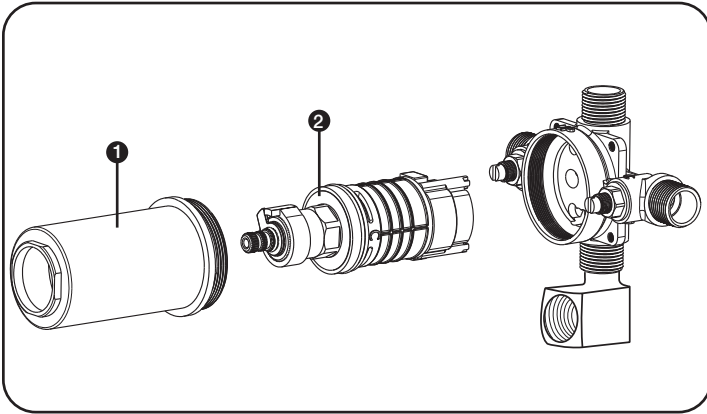

To adapt your shower valve for back-to-back installation:

1. Use an adjustable wrench to remove the bonnet (1), and cartridge assembly (2).
2. Rotate valve cartridge 180° and reinstall into valve body taking care to properly align the mounting posts of the cartridge with the corresponding holes within the valve. The “H” marking on valve cartridge cover should now be on the right hand side.
3. Reinstall bonnet, making sure the large bonnet o-ring is in place within the valve body.

Setting Limit Stop

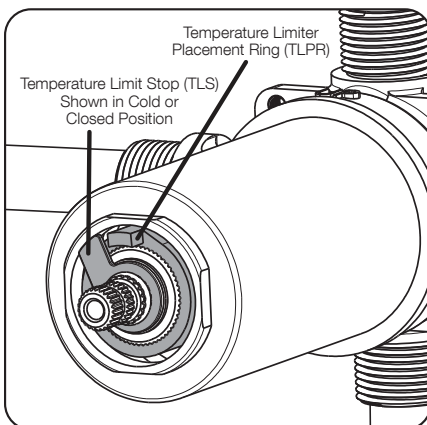

To properly set the limit ring, you must use a thermometer or calibrated sensing device to accurately measure the outlet water temperature. The adjustment ring is positioned as follows:

The valve has been factory set at 120° F. Important: Check each valve installation with a thermometer to make sure the maximum hot water temperature is set to the recommended setting per location/installation requirement. To lower the limit of the maximum hot water temperature the valve delivers, adjust the valve’s temperature limit stop (TLS) plate.

1. Slip the retaining O-ring and the TLS plate towards the end of the spindle and remove the Temperature Limiter Placement Ring.
2. With the water supplies on, rotate the Cartridge spindle counter-clockwise to the maximum desired hot water temperature.
3. Position the TLS plate and TLPR so it contacts the TLPR lug and therefore restricts the counter-clockwise rotation of the spindle.
4. Slip the retaining O-ring back into the groove of the Cartridge spindle to hold the TLS plate in place.
5. Rotate the spindle clockwise to the “OFF” position.

Standard Mixing Valve Trim Installation

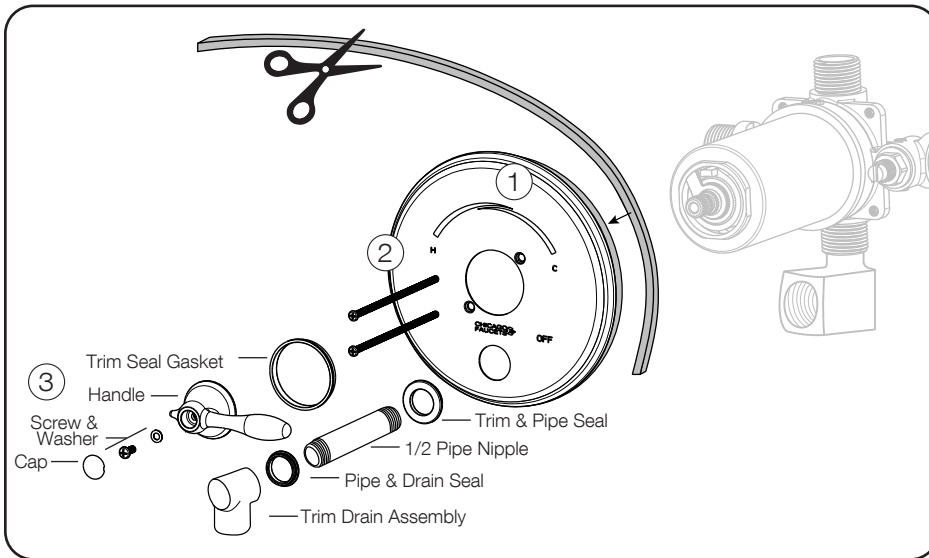

Follow "Setting Limit Stop" instructions below before proceeding.

1. Attach foam seal to back of trim plate along outer edge.
Cut to size leaving 1/8" gap at the bottom of the plate.
2. Align face plate with mounting holes on valve and attach with screws.
3. Attach handle. Make sure it is positioned in "OFF" position.

Standard Diverter Valve Trim Installation

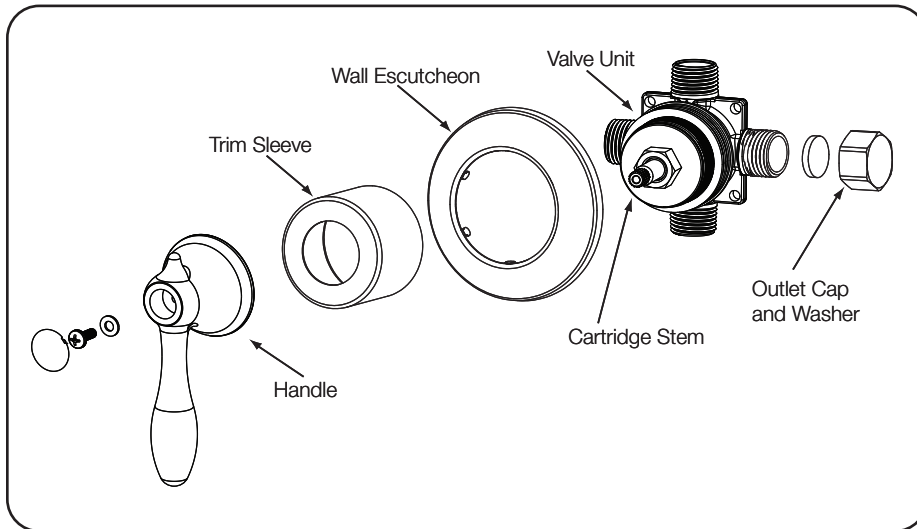

1. Before installing the valve trim, be sure the final wall finish is completely installed. The wall surface should be level, clean, and dry.
2. Remove the trim sleeve from the trim pack and slide it over the valve unit, seating it flush to the valve (see Figure 4).
3. Remove the wall escutcheon from the trim pack and slide it over the trim sleeve.
4. Attach handle. Make sure that the handle stem is pointing directly down when assembled.

The handles are designed to rotate at 90 degrees in a clockwise and counter-clockwise movement. Rotate the handle in the clockwise and counter-clockwise direction to verify that the handle stops in the 90-degree position in both directions.

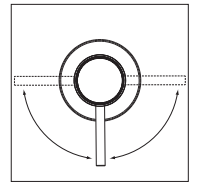

Care and Maintenance

All Chicago Faucets fittings are designed and engineered to meet or exceed industry performance standards. Care should be taken when cleaning this product. Do not use abrasive cleaners, chemicals or solvents as they can result in surface damage. Use mild soap with warm water for cleaning and protecting the surface of Chicago Faucets fittings.

For additional technical assistance, call 800/TEC-TRUE (800-832-8783) or visit our website at chicagofaucets.com.

CHICAGO FAUCETS LIMITED WARRANTY

TO WHOM DOES THIS WARRANTY APPLY? — The Company extends the following limited warranty to the original user only.

WHAT DOES THIS WARRANTY COVER AND HOW LONG DOES IT LAST?

This warranty covers the following Chicago Faucets branded Products:

LIFETIME WARRANTY — Any metal cast, forged, stamped or formed portion of the Product, not including electronic or moving parts or other products separately covered by this Limited Warranty or water restricting components or other components, is warranted against material manufacturing defects for the life of the Product.

FIVE YEAR WARRANTY — Certain Products or portions of the Product are warranted against material manufacturing defects for a period of five (5) years from the date of Product purchase. Products warranted against material manufacturing defects for a period of five (5) years from the date of Product purchase are referred to by the product series 90, 99, 150, 410, 420, 430, STB, STC, W4D, W4W, W8D, W8W, 1900, 1905, SH, 537, 548, 549, 640, 897, 2500, 8400, 9800 and E-Tronic™.

FIVE YEAR CARTRIDGE WARRANTY — The "Cartridge", defined as the metal portion of any Product typically referred to by the product numbers containing 1-099, 1-100, 217, 274, 313, 333, 335, 376, 377, 386, 408, 409, 617, 625, 628, 667, 670, 671, 672, 745, 776, 807, 824, 825, 826, 919, 937, 962, 966, 977, 1105, 2500, 3300 and 5235 excluding any rubber or plastic components, is warranted against material manufacturing defects for a period of five (5) years from the date of Product purchase.

ONE YEAR FINISH WARRANTY - COMMERCIAL — For Products used in commercial applications, the finish of the Product is warranted against material manufacturing defects for a period of one (1) year from the date of Product purchase.

OTHER WARRANTIES — All other Products not covered above are warranted against material manufacturing defects for a period of one (1) year from the date of Product purchase.

Other restrictions and limitations apply. For complete warranty details, call Chicago Faucets Customer Service at 847-803-5000 or visit chicagofaucets.com.

The Chicago Faucet Company
2100 South Clearwater Drive
Des Plaines, IL 60018
Phone: 847/803-5000
Fax: 847/803-5454
Technical: 800/832-8783
www.chicagofaucets.com